

→ AS-9PCHD (NUZ09S)

Extra-wide platform
Crawler type / Telescopic boom lift

FEATURES

- ✓ Low emission
- ✓ Overload sensing
- ✓ Max platform capacity 600kg
- ✓ Operation restriction (slope)

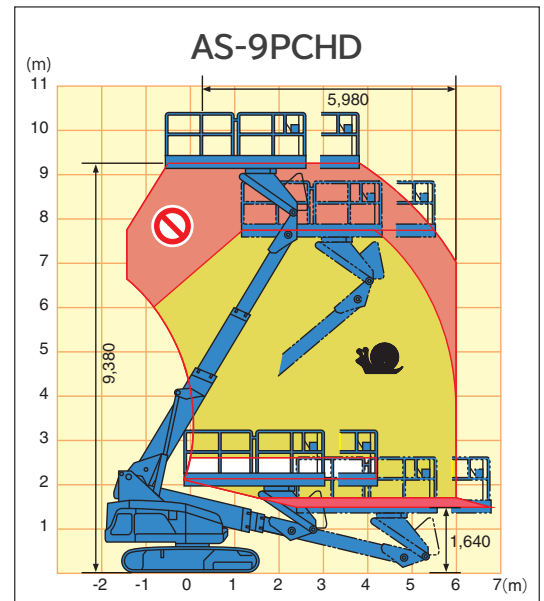

TYPE	AS-9PCHD
Platform capacity	600 kg
Allowable tilt	3°
Platform dimensions (W x L x H)	2,050 x 3,150 x 1,000 mm
Platform height (max)	9,380 mm
Horizontal reach	5,980 mm
Machine weight (w/pad)	8,900 (9,140) kg
Overall length	5,045 mm
Overall width	2,250 mm
Overall height	3,340 mm
Engine model	KUBOTA D1305
Travel speeds	1.0/1.5/2.5 km/h

Lifting the machine

- ⚠ Use only qualified rigging to hoist the machine.
- ⚠ Be sure that lifting devices and crane are sufficient to withstand the machine weight.
- Ensure the boom is in stowed position and turntable locked with slewing lock-pin before lifting.
- Determine the center of gravity of the machine as shown below.
- Attach the rigging to designated lifting rings on the machine.
- Insert protective materials where rigging may interfere with the machine.

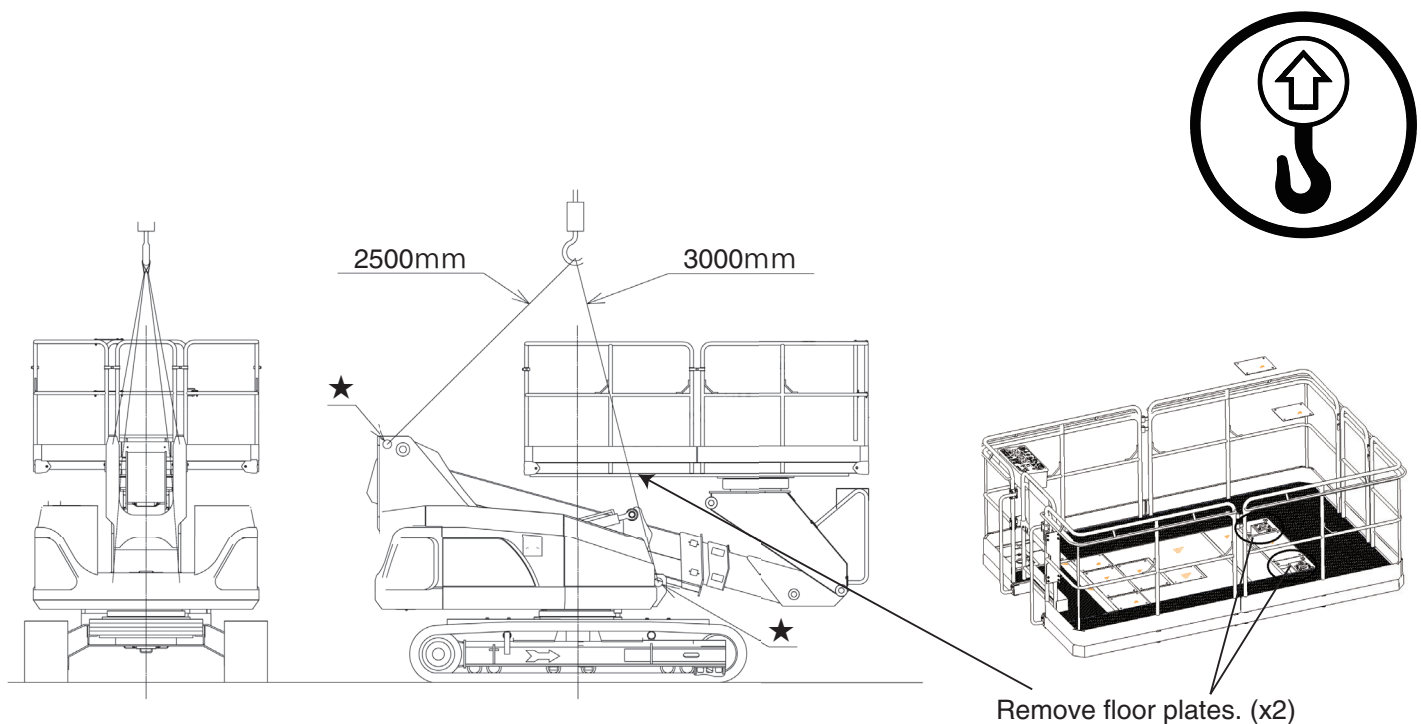

Tadano Ltd.

Kanda Square 18th Floor, 2-2-1 Kanda-Nishikicho, Chiyoda-ku, Tokyo 101-0054, Japan

Phone: +81-3-6811-7309

info@tadano.com

www.tadano.com