

## → AA-12P (NUL12W)

Wheel type  
Articulated boom lift

### FEATURES

- ✓ Low emission
- ✓ Zero / Short tail
- ✓ Total range traveling
- ✓ Allowable tilt 5° (option)

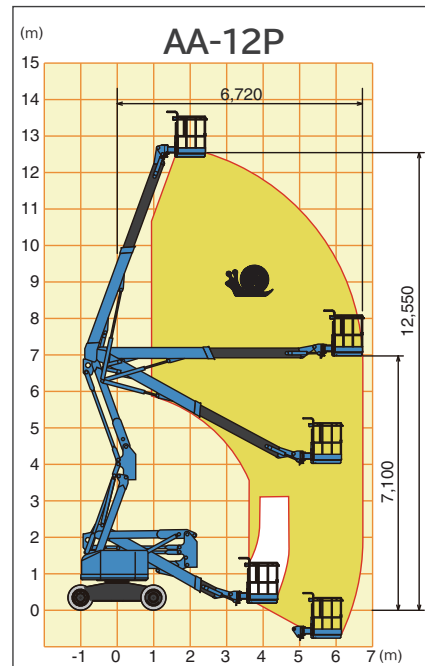

TYPE	AA-12P
Platform capacity	200 kg
Allowable tilt	3°
Platform dimensions (W x L x H)	1,130 x 730 x 1,000 mm
Platform height (max)	12,550 mm
Horizontal reach	6,720 mm
Machine weight	5,305 kg
Overall length	5,780 mm
Overall width	1,980 mm
Overall height	2,330 mm
Engine model	KUBOTA D1105
Travel speeds	0.9/3.0/5.0 km/h

## Lifting the machine

- ⚠ Use only qualified rigging to hoist the machine.
- ⚠ Be sure that lifting devices and crane are sufficient to withstand the machine weight.
- Ensure the boom is in stowed position before lifting.
- Determine the center of gravity of the machine as shown below.
- Attach the rigging to designated lifting rings on the machine.
- Insert protective materials where rigging may interfere with the machine.

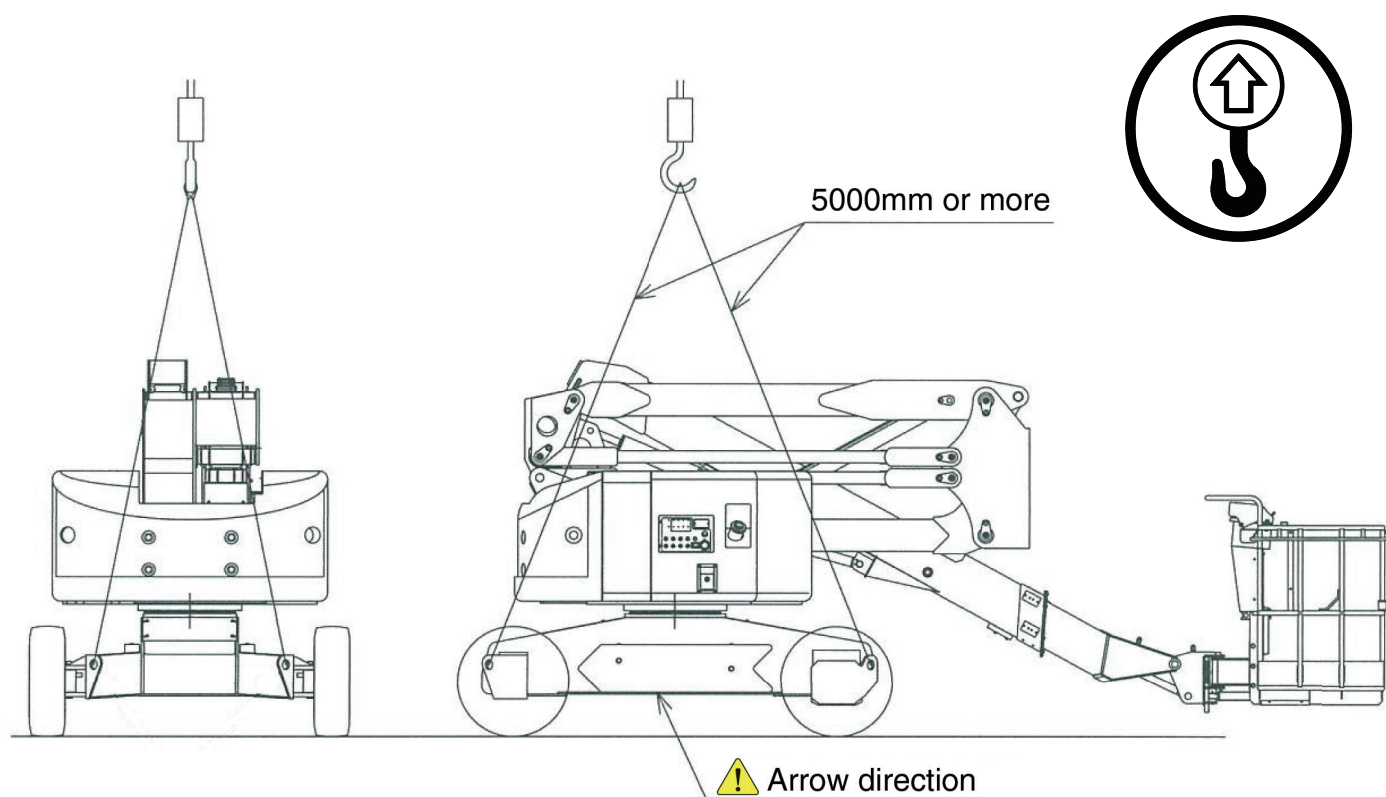

## Tadano Ltd.

Kanda Square 18th Floor, 2-2-1 Kanda-Nishikicho, Chiyoda-ku, Tokyo 101-0054, Japan

Phone: +81-3-6811-7309

info@tadano.com

www.tadano.com